



**FlxGen™ SDR/DSP Receivers
and Downconverters
for SIGINT Applications**

Elcom
Technologies

ISO 9001 : 2008

FlxGen™ is a new flexible generation of high performance SIGINT sensors

FlxGen is a new-generation of flexible, high-performance SIGINT sensors that combines proprietary RF topologies from Elcom Technologies with commercial off-the-shelf (COTS) DSP hardware. These advanced SIGINT sensors feature a host of benefits such as greatly enhanced signal detection sensitivity and selectivity. With their modular design, these SIGINT sensors are ideal for meeting custom or semi-custom requirements with a variety of form factors, such as VME, VXI and 1U. Time to prototype is also reduced while minimizing NRE.

The outstanding signal detection and demodulation performance of these SIGINT sensors results from years of EW experience in developing RF architectures with nanosecond switching speeds and low phase noise. By incorporating digitally selectable intermediate frequencies (IFs), these SIGINT sensors **offer the versatility to replace multiple legacy receivers with a single unit** to help lower system-level equipment, support and maintenance costs. Elcom's track record in fast-switching synthesizers provides the basis for these ultrafast scanning SIGINT sensors with their effective signal-collection capabilities.

Elcom's SIGINT sensors feature custom algorithms and specialized circuit topologies to improve adjacent-channel selectivity and minimize spurs. The result is impressive signal sensitivity that can extract the weakest signals of interest from dense signal environments. This detection capability is combined with an RF-DSP architecture designed to provide processing flexibility **such as direct I/Q over Ethernet data transfer, SNR detection and programmable detection** of specific signal classifications. In addition, the flexibility of Elcom's SIGINT sensors is enhanced further by quick upgrades through remote software downloads and user-programmable processing algorithms.

FlxGen™ Operating Frequency Range

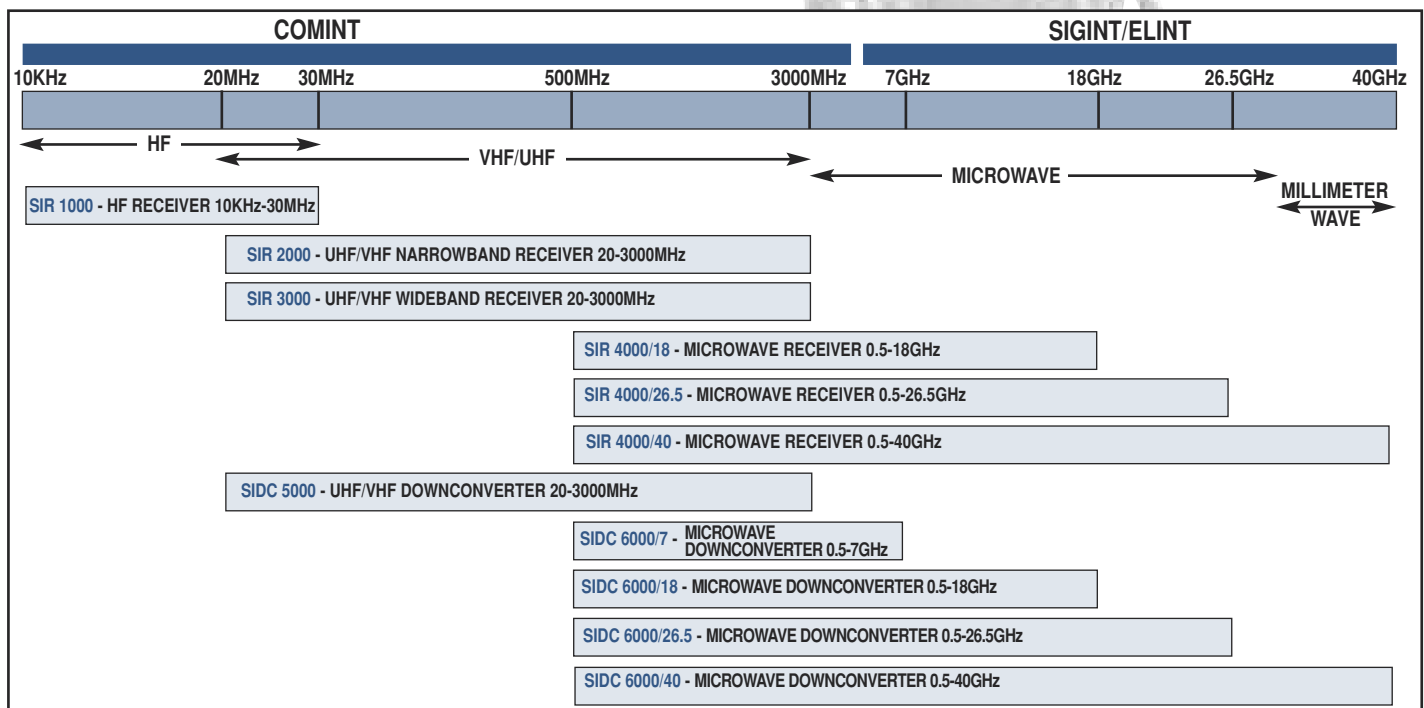

HF Receivers



SIR 1000 HF Receiver

- Frequency Range 10 KHz to 30 MHz
- 100 dB Spurious Free Dynamic Range
- Input IP3 > 30 dBm
- AM, FM, CW, USB, ISB, LSB Demodulation
- Noise Figure 14 dB
- Selectable IF BW (150 Hz, 300 Hz, 600 Hz, 1.2 KHz, 9.6 KHz)
- Digital IQ Over Ethernet
- Tuning Speed - 1 msec (200 Microsecond optional)
- 455 KHz IF Output

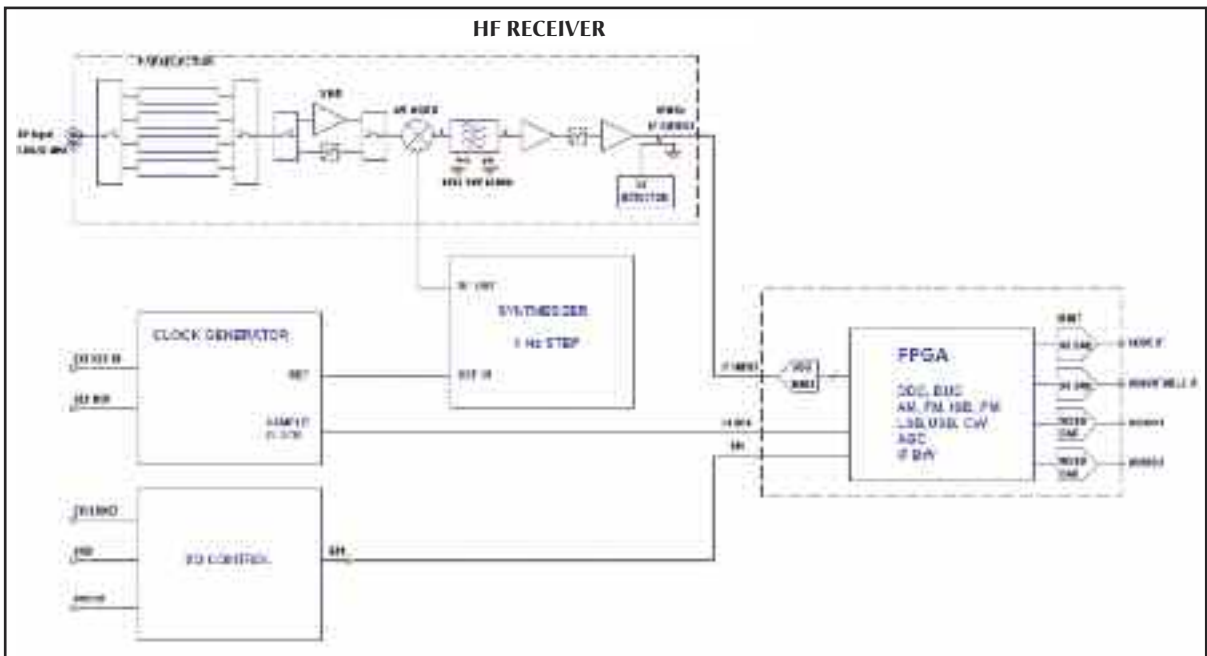

VHF/UHF Receivers and Downconverters

SIR 2000 Narrowband VHF/UHF Receiver

- Frequency Range 20 MHz to 3000 MHz
- High Dynamic Range: 80 dB SFDR, In Band IP3 > +5 dBm
- IF BW From 6 KHz to 500 KHz (1-10 MHz Optional)
- AM, FM, CW Demodulation
- Digital IQ Over Ethernet
- Tuning Speed 1 msec (Faster Tuning Optional)
- Low Power Consumption



SIDC 5000 VHF/UHF Downconverter

- Frequency Range 20 MHz to 3000 MHz
- Tuning Speed < 200 Microseconds
- 80 dB Spurious Free Dynamic Range
- Input IP3 > 10 dBm
- IF Center Frequency 21.4 MHz (70 MHz and 10.7 MHz Optional)

SIR 3000 Wideband VHF/UHF Receiver

- Frequency Range 20 MHz to 3000 MHz
- High Dynamic Range: 80 dB SFDR
- Extremely Wide Band IF – Up To 80 MHz Bandwidth
- Sweep – Scan up to 512 Channels /second
- Fast Tuning VCO Based Synthesizer
- AM, FM, CW, PM Demodulation
- Center Frequency 21.4 MHz (70 MHz and 10.7 MHz Optional)
- SNR Detection Squelch

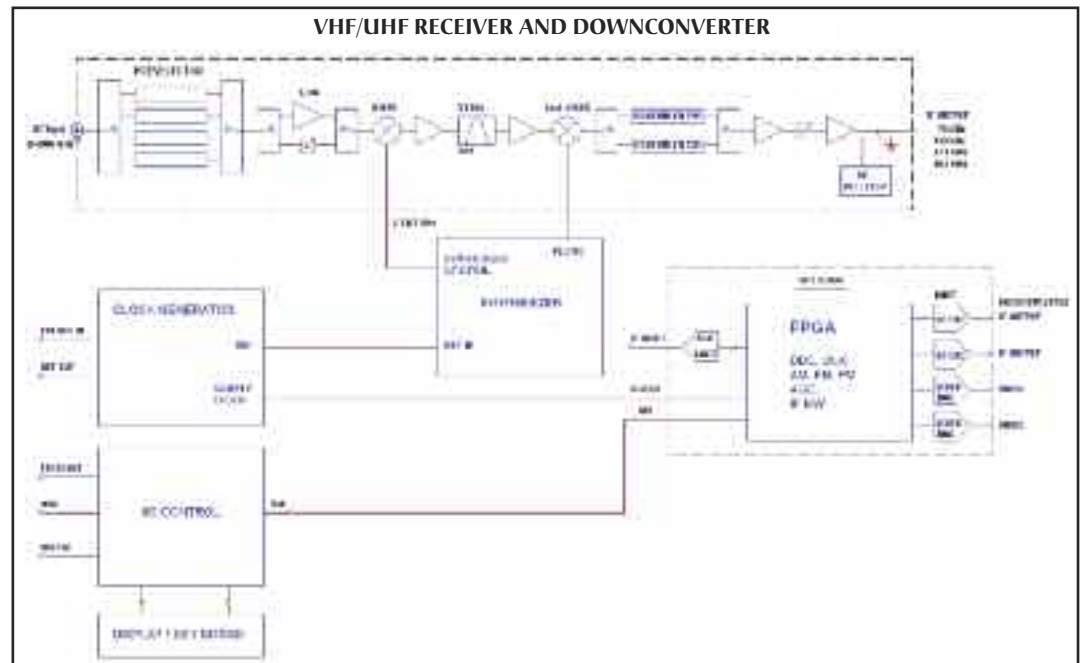

Microwave Receivers and Downconverters

SIR 4000

Microwave Receiver

- Frequency Range 0.5 – 18 GHz / 26.5 GHz/ 40 GHz
- High Dynamic Range Input IP3 > 5 dBm
- Selectable CF IF Output (70/140/160 MHz)
- 8 Selectable IF BW From 0.5 MHz to 80 MHz
- L band Output, 500 MHz BW (Up to 1 GHz Optional)
- Tuning Speed (100 Milliseconds Max / 50 Microseconds in Scan Mode)
- Noise Figure 15 dB Max
- AM, FM Demodulation
- Digital IQ Over PCI-Express



SIDC 6000

Microwave

Downconverter

- Frequency Range 0.5 – 7 GHz / 18 GHz / 26.5 GHz/ 40 GHz
- High Dynamic Range Input IP3 > 5 dBm
- Selectable CF IF Output (70/140/160 MHz)
- 8 Selectable IF BW From 0.5 MHz to 80 MHz
- L band Output, 500 MHz BW (Up to 1 GHz Optional)
- Tuning Speed (100 Milliseconds Max / 50 Microseconds in Scan Mode)
- Noise Figure 15 dB Max

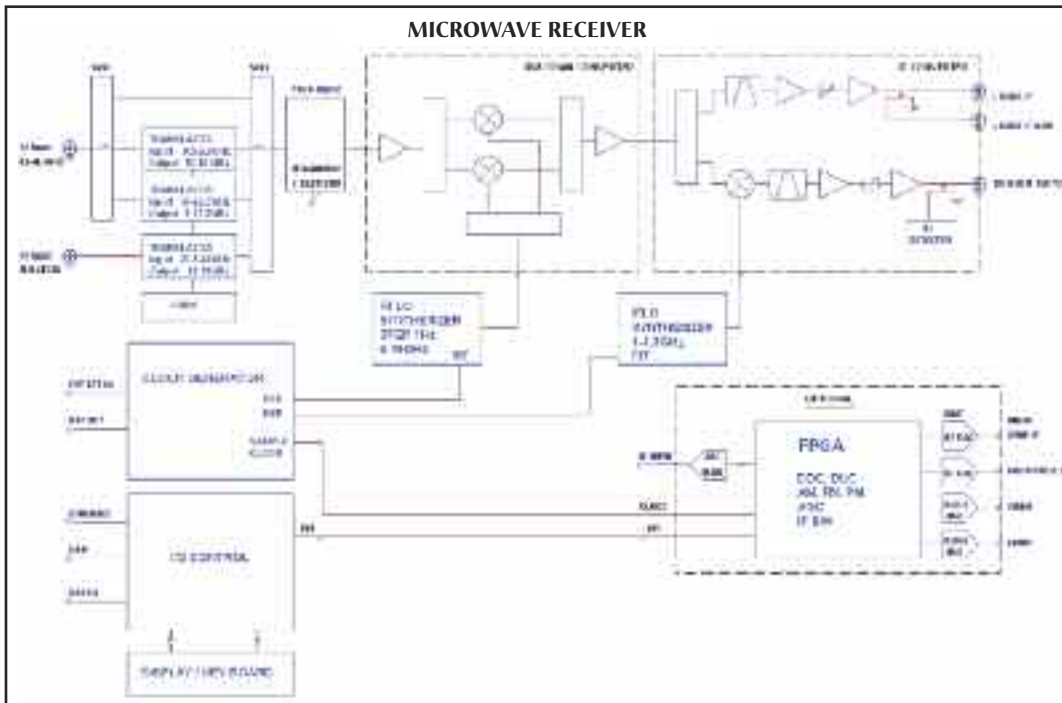

Elcom Technologies is a US company headquartered in New Jersey and is ITAR compliant. During the last ten years Elcom has developed a customer base that includes every major aerospace



defense company in the United States and several commercial companies in test and measurement, SATCOM and telecommunications. Our knowledge of direct analog synthesis and SDR Digital Signal Processing has produced industry leading RF performance in SIGINT applications. Customer benefits are low phase noise, signal sensitivity and selectivity, key mission critical parameters.

In-House Environmental Test Capabilities

Elcom's HALT (Highly Accelerated Life Testing) and HASS (Highly Accelerated Stress Screening) systems use omni-directional vibration control and provide evaluation capabilities within six degrees of freedom. The technology features temperature control from -100C to +200C and can apply forces exceeding 50 G's simulating even the harshest operating environments. Products are subjected to increasing stress levels in both temperature and vibration (independently and in combination), plus rapid thermal transitions and other stresses related to the specific operation of your product. These capabilities allow Elcom to precisely determine failure modes and the root causes of functional operating limits including critical functional destruct limits.

ELCOM Technologies

11 Volvo Drive
Rockleigh, NJ 07647

TEL: 201.767.8030 x 286

FAX: 201.767.1326

E-MAIL: sales@elcom-tech.com

www.elcom-tech.com

Elcom
Technologies
ISO 9001 : 2008